

# Enclosed UniModule Installation and Technical Procedures Regular and Washdown Models EUM-50/EUM-100/EUM-180/EUM-210/EUM-215

P-226  
819-0355

Installation & Operating Instructions



An Altra Industrial Motion Company

## Contents

Pre-Installation Instructions . . . . .	2
Installation Instructions . . . . .	3
Electrical Coil Data, Mechanical Data . . . . .	7
Overhung Load Data. . . . .	7
Pre-Burnishing & Maintenance . . . . .	8
Troubleshooting . . . . .	9
Dimensions EUM-1020 . . . . .	10
Dimensions EUM-2030 . . . . .	11
EUM Parts List/1020 Combinations . . . . .	12
EUM Parts List/2030 Combinations . . . . .	14
Warranty . . . . .	Back Cover

**⚠ WARNING** Failure to follow these instructions may result in product damage, equipment damage, and serious or fatal injury to personnel.

## Pre-Installation Instructions

- A. The Enclosed UniModule has been designed to NEMA standards and can be installed with all standard power transmission drive systems.
- B. Before installing the Enclosed UniModule to a motor or reducer, make certain that the EUM size and NEMA frame dimensions match according to the chart on the right.
- C. Check the motor for shaft endplay. If the shaft can be moved axially .030" or more, the module should not be installed since excessive thrust may occur between the rotor and field. The motor should not be used unless the endplay can be reduced.

## Introduction

This manual covers installation, wiring and troubleshooting of regular and washdown models of Enclosed UniModule clutch/brake sizes 50, 100, 180, 210, and 215. Washdown models are designed to be liquid tight under normal washdown conditions and the special instructions required to install these products follow with the instructions for the regular units. Mechanical and electrical specifications and dimension drawings are included.

**⚠ WARNING** Make sure all power is turned off to this equipment when installing, as injury (or even death) may result from contact with live wires or rotating shafts.

EUM Size	Corresponding NEMA Frame Size		Shaft Dia.	C-Face Pilot Dia.
	Old NEMA	New NEMA		
50	56 C	48 Y	5/8"	4-1/2"
100	56 C	48 Y	5/8"	4-1/2"
180	182 C	143 TC	7/8"	4-1/2"
	184 C	145 TC		
210	213 C	182 TC	1-1/8"	8-1/2"
	215 C	184 TC		
215		213 TC	1-3/8"	8-1/2"
		215 TC		

---

**For these EUM combinations:****Use these installation steps:**

---

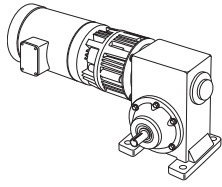

Enclosed UniModule Clutch-Brake Between  
C-Face Motor and Reducer – 1020

1, 2, 3, 4, 7

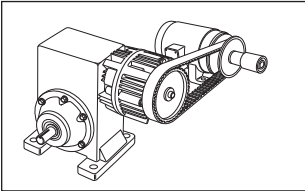

Enclosed UniModule Clutch-Brake – 2030

4, 7

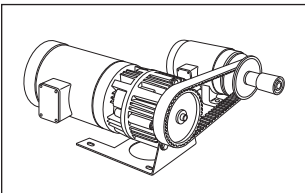

Motor Mount Enclosed UniModule Clutch-Brake  
On C-Face Motor – 1020-M

1, 2, 3, 6, 7

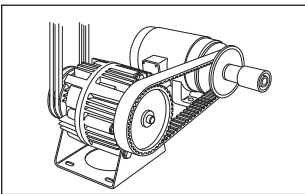

Base-Mounted  
Enclosed UniModule Clutch-Brake – 2030-B

5, 7

---

## Installation Instructions

Warner Electric's Enclosed UniModule has been designed to NEMA standards and can be installed with all standard power transmission drive systems. Before installing the Enclosed UniModule to a motor or reducer, make certain that the EUM size and NEMA frame dimensions match according to the chart.

Install your specific modular combination according to the installation steps specified in the table on page 2. Use only those steps indicated for each combination.

**Note:** The equipment covered by this service manual must be installed in accordance with these instructions. Failure to do so may damage the equipment and void the warranty.

**Note:** Special plugs and plastic screws are provided with each washdown kit. All unused holes are to be plugged to prevent debris buildup and to ensure that the clutch/brake stays dry.

## Mounting To A Motor

### Step 1:

#### A. For Washdown Models Only:

1. Slip rubber shield (seal) over clutch and end of module; exact position of rubber band is described in step 3.B. Place gasket between motor and clutch end; be sure to select correct gasket to match clutch end.

**B. For All UniModule Models**

**Note:** The 1020 UniModule is furnished with a special key already assembled in the rotor hub. Do not use another key!

1. Before sliding UniModule onto motor, align set screws on rotor input hub to access slots on clutch side of module. Insert into a set screw and slide assembly onto motor shaft as shown in Figure 2. Align key in UniModule with motor shaft keyway.



Figure 2

Do not use force. If UniModule does not slide on freely, polish motor shaft sufficiently to achieve a slip fit.

**Note:** Sizes 100, 210 and 215 UniModules require an adapter ring to be mounted to the motor prior to mounting the 1020 UniModule. Adapter and mounting hardware are provided with the UniModule assembly.

**Step 2:**

**A. For UniModule Models Other Than Washdown**

1. Insert four large capscrews with lock washers provided through mounting holes in housing and into tapped holes on motor face. Tighten alternately and securely to 30 to 35 ft. lbs. torque. See Figure 3.

**B. For Washdown Models Only**

1. Insert four large capscrews provided through the large plastic washers and through mounting holes in housing and into

tapped holes on motor face. Tighten alternately and securely to 30 to 35 ft. lbs. torque. See Figure 3.



Figure 3

**Step 3:**

**A. For All UniModule Models**

1. Tighten both set screws on the module input hub with prepositioned Allen wrench alternately and securely to 80 to 85 in. lbs. for all sizes. See Figure 4.

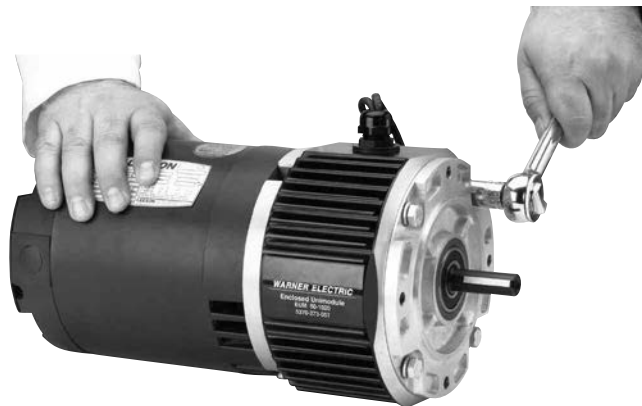

Figure 4

**B. For Washdown Models Only**

1. After tightening set screws on the rotor input hub, Figure 3, use plastic screws provided in the kit to plug threaded holes and position rubber seal to cover all slots.

**Step 4: Mounting to a Reducer**

The output side of a UniModule may be mounted directly to a reducer.

**A. For Washdown Models Only**

1. Place a gasket between reducer and clutch/brake; select correct gasket to match brake end configuration. See Figure 5.



Figure 5

**B. For All UniModule Models**

1. Align output shaft and key of UniModule with corresponding shaft hole and keyway of reducer. Slide assembly together, matching pilot diameter on UniModule with a pilot diameter on reducer. See Figure 6.



Figure 6

2. Bolt UniModule to reducer flange. The four bolts required (3/8-16 UNC-2A) are normally furnished with the reducer. Tighten to 18 to 22 ft. lbs. torque for 50 and 180 size, 40 to 45 ft. lbs. torque for 210 and 215 sizes.

**Step 5: Installing the Base Mount on 2030 UniModules**

**A. For All UniModule Models**

1. Mount each UniModule so that base is located below ventilation holes. A pilot diameter on end of each UniModule mates with pilot diameters on base. See Figure 7.
2. Secure base to UniModule with the bolts provided. Tighten to 18 to 22 ft. lbs. torque for 50 and 180 sizes, 40 to 45 ft. lbs. torque for 210 and 215 sizes.

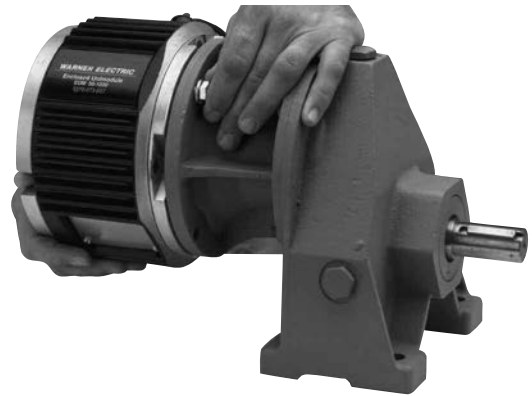

Figure 7

**Step 6: Installing the Motor Mount (M)**

Motor Mount (M) can be installed to output end of UniModule to provide a foot mounting for complete assembly of UniModule and motor.

**A. For All UniModule Models**

**Sizes 50, 100 and 180**

1. Remove the four set screws plugging the mounting holes. Remove the two long hex head bolts from side of UniModule toward ventilation holes.
2. Mount UniModule on Motor Mount so base of Motor Mount is underneath UniModule and motor. See Figure 8. A pilot diameter on UniModule mates with a pilot diameter on Motor Mount.
3. Secure Motor Mount in place with two longer mounting bolts. Tighten to 30 to 35 ft. lbs. torque and two shorter bolts tighten 18 to 22 ft. lbs. torque, all provided in kit.

**Sizes 210 and 215**

1. Mount UniModule on Motor Mount so base of Motor Mount is underneath UniModule

and motor. See Figure 8. A pilot diameter on UniModule mates with a pilot diameter on Motor Mount.

- Secure Motor Mount to the UniModule with three bolts provided and tighten to 40 to 45 ft. lbs. torque.



Figure 8

#### B. For Washdown Models Only

- If any mounting bolts are not used, make sure the mounting holes are plugged with the .437 diameter plugs provided. For 210 and 215 size units, make sure holes on circumference are plugged with the .375 plugs provided.

#### Step 7: Electrical Connections

**⚠ WARNING** To avoid injury (or even death) always make certain all power is off before attempting to install or service this control or any electrical equipment.

#### A. For All UniModule Models

- The UniModule is provided with one conduit connection hole, threaded for standard 1/2" conduit connectors. Both the clutch and brake lead wires are brought out through this opening. The conduit box accessory kit, P/N 5370-101-042 for non-washdown models, and 5370-101-045 for washdown models, provides two conduit connection holes for standard 1/2" conduit connectors.

The clutch and brake coils operate on DC voltage. Warner Electric offers a full line of AC voltage powered controls to meet the needs of almost every clutch/brake application. The service and installation instructions included with each Warner

Electric control show the proper electrical connections.

Please refer to Figure 9 for the proper UniModule electrical connections. **Clutch and brake leads are identified with labels.**

#### B. For Washdown Model Only

- Use only liquid tight connectors with flexible tubing for connections.

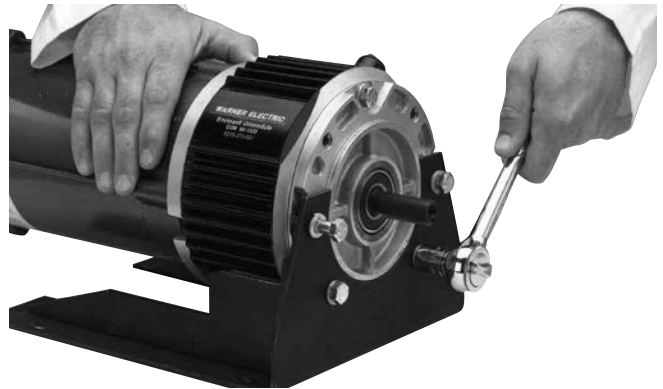
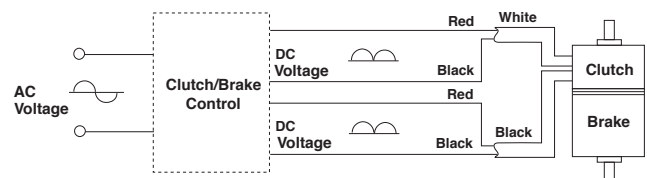

Figure 9

After wiring, your Enclosed UniModule is now ready to operate. If your clutch/brake control has torque control, the torque adjust potentiometer(s) should be set for rapid and complete load take up. Excessive slippage of the brake or clutch can cause overheating and premature wear. For additional information, including the armature adjustment which is occasionally required for new installations, see page 7 of this manual.



## Electrical Coil Data

Voltage–D.C.		Clutch Brake		Clutch Brake		Clutch Brake	
		90	90	24	24	6	6
Resistance	EUM-50	452	452	31.8	31.8	1.86	1.86
(OHMS)	EUM-100	362	362	26.7	26.7	1.9	1.9
	EUM-180	362	362	26.7	26.7	1.9	1.9
	EUM-210	264	264	17.9	17.9	1.33	1.33
	EUM-215	264	264	17.9	17.9	1.33	1.33
Amperes	EUM-50	.199	.201	.755	.755	3.23	3.23
	EUM-100	.249	.249	.896	.896	3.1	3.1
	EUM-180	.249	.249	.896	.896	3.1	3.1
	EUM-210	.341	.341	1.34	1.34	4.5	4.5
	EUM-215	.341	.341	1.34	1.34	4.5	4.5
WATTS	EUM-50	18	18	18	18	19	19
	EUM-100	22	22	21.5	21.5	19	19
	EUM-180	22	22	21.5	21.5	19	19
	EUM-210	30.7	30.7	32	32	27	27
	EUM-215	30.7	30.7	32	32	27	27
Build Up	EUM-50	52	53	52	53	52	53
(Milli-	EUM-100	72	75	72	75	72	70
seconds)	EUM-180	72	75	72	75	72	70
	EUM-210	120	100	120	100	110	100
	EUM-215	120	100	120	100	110	100
Decay	EUM-50	6.2	5.0	6.2	5.0	6.5	5.0
(Milli-	EUM-100	12	10	12	10	12	10
seconds)	EUM-180	12	10	12	10	12	10
	EUM-210	20	10	20	10	20	10
	EUM-215	20	10	20	10	20	10

## Mechanical Data

	EUM-50	EUM-100	EUM-180	EUM-210	EUM-215
Static Torque	16 lb. ft.	16 lb. ft.	30 lb. ft.	95 lb. ft.	95 lb. ft.
Maximum Speed	3600 rpm	3600 rpm	3600 rpm	3600 rpm	3600 rpm
Average Wt. -lbs.					
Motor Clutch	3.4 lbs.	5.1 lbs.	5.1 lbs.	9.1 lbs.	9.1 lbs.
Brake	6.6	8.1	8.1	21.5	21.5
Input Clutch	6.4	8.4	8.4	19.8	19.8
Output Clutch	4.9	5.2	5.2	15.2	15.2
Inertia – WR					
Armature	.007	.018	.018	.081	.081
	lb. ft.	lb. ft.	lb. ft.	lb. ft.	lb. ft.
Armature hub	.002	.003	.003	.021	.021
Shaft	.001	.002	.002	.017	.017
Rotor w/Fan					
and hub	.020	.046	.046	.188	.188

## Overhung Load Data

Overhung load data is provided in this manual for the design engineer concerned with specific requirements in this area. The maximum allowable overhung load which can be applied to the shaft of a UniModule may be determined by the use of the accompanying chart.

Module Size	Distance Load is Applied from Housing Face "A" Inches	Maximum Load Rating "R" lbs.
EM-50	1" – Center of Shaft	177
EUM-50	2" – End of Shaft	123
	3"	95
EM-100	1" – Center of Shaft	177
EUM-100	2" – End of Shaft	123
	3"	95
EM-180	1" – Center of Shaft	192
EUM-180	2" – End of Shaft	134
	3"	104
EM-210	1-3/8" – Center of Shaft	386
EUM-210	2-3/4" – End of Shaft	271
	4-1/8"	208
EM-215	1-3/8" – Center of Shaft	386
EUM-215	2-3/4" – End of Shaft	271
	4-1/8"	208

Based on 10,000 Hour Life at 3600 RPM.

The minimum pitch diameter pulley or sprocket that can be used, for satisfactory bearing life, is determined from the formula:

$$\text{Min. P.D.} = \frac{2TK}{R}$$

T – Torque (in. lbs.). This is the torque actually being transmitted, not necessarily the maximum torque capacity of the Electro-Module.

$$\text{Torque} = \frac{63025 \times \text{HP}}{\text{RPM}}$$

K – The safety factor for the tension in the type of drive.

Use: 1 chain and sprocket  
1 for timing belt  
2 for V-belt  
3 for flat belt

R – Radial load allowable (values at various distance from the housing face are given in the chart).

**Example:** What is the minimum V-belt pulley that can be applied to the center of the shaft of an EM-50 module. The torque requirement is 112. in. lbs.

$$\text{Min. P.D.} = \frac{2 \times 112 \times 2}{224} = 2'' \text{ minimum P.D. pulley}$$

## **Pre-Burnishing and Maintenance**

### **Pre-Burnishing**

All Warner Electric UniModules are pre-burnished before leaving the factory and are designed to pull full torque as shipped. Like all friction based products, their consistency will improve after a short break-in period.

### **Maintenance**

As with any friction-type device, some initial care should be given to wear rate, as minor adjustments in actuation time can sometimes extend the life of the unit.

The exploded views and drawing illustrate and describe the various components in each Electro-Module.

### **Wear Pattern**

Wear grooves appear on the friction surfaces. This is a normal wear condition, and does not impair functioning of the unit. Never machine the friction surfaces to remove grooves or score marks resulting from normal wear.

### **Heat**

Excessive heat and high operating temperatures are causes of rapid wear. Units, therefore, should be ventilated as efficiently as possible, especially if the application requires fast, repetitive cycle operation.

### **Foreign Materials**

Do not spray internal friction surfaces with oil. EUMs will withstand humid, wet environments. The washdown version is able to withstand high pressure wash applications.

### **Torque Loss**

If a brake or clutch module slips or loses torque completely, the initial check should be the input voltage to the magnet or field as follows:

**90-Volt:** Connect a DC voltmeter with a range of 0-100 volt directly across the magnet or field terminals. With the power on and the potentiometer turned up, a normal reading is 90 volts, although 85 to 95 is satisfactory. The reading should drop as the potentiometer control is adjusted counterclockwise.

**6-Volt:** Use a DC voltmeter of approximately 0-15 volt range. A normal reading is from 5.5 to 6.5 volts, depending on the power supply.

The above checks normally are sufficient. Further checks may be made as follows: a low range ammeter, when connected in series with one magnet lead, will normally indicate 0.2 to .35 amperes for the 90 volt units and 3.0 to 4.5 for the 6 volt series. These readings are with the power on and the potentiometer control in the maximum position.

Ohmmeter checks should be made with the power off and the circuit open. (To be certain, disconnect one lead to the magnet.) Compare resistance to the data on page 8.

If the above checks indicate that the proper voltage and current is being supplied to the coil, mechanical parts should be checked to assure that they are in good operating condition and properly installed.



## Troubleshooting

With the motor at rest and locked out, check the following:

- A. Spin the output shaft by hand to ensure that it turns freely.
- B. If the unit fails to engage, first check the power supply. Then remove the four screws of the access panel on the side of the unit. With full voltage applied to the clutch or brake, switch back and forth between the clutch and brake and observe the armatures (plates) through the access hole. They should move back and forth approximately 1/32" when switched.
- C. If a scraping sound is noted when the output shaft is spun, it means an armature is dragging slightly because of shock and displacement during shipment. This is easily corrected.

Remove the four screws of the access panel on the side of the unit. Insert a screwdriver through the access hole and pry the dragging armature (clutch or brake as observed) away from the mating surface evenly all the way around as far as it will move. Then apply power to the magnet and insert the screwdriver between the two armatures (back to back) to nudge them evenly back into complete contact. Pry only on the outer edge of the armature to avoid damaging the autogap assembly. This will reset the autogap in the proper position and the unit should now be ready for further assembly in the drive system and normal operation. See Figure 10.

Replace the access panel on the assembly.



Figure 10

# Enclosed UniModule Combinations

## Dimensions EUM-1020

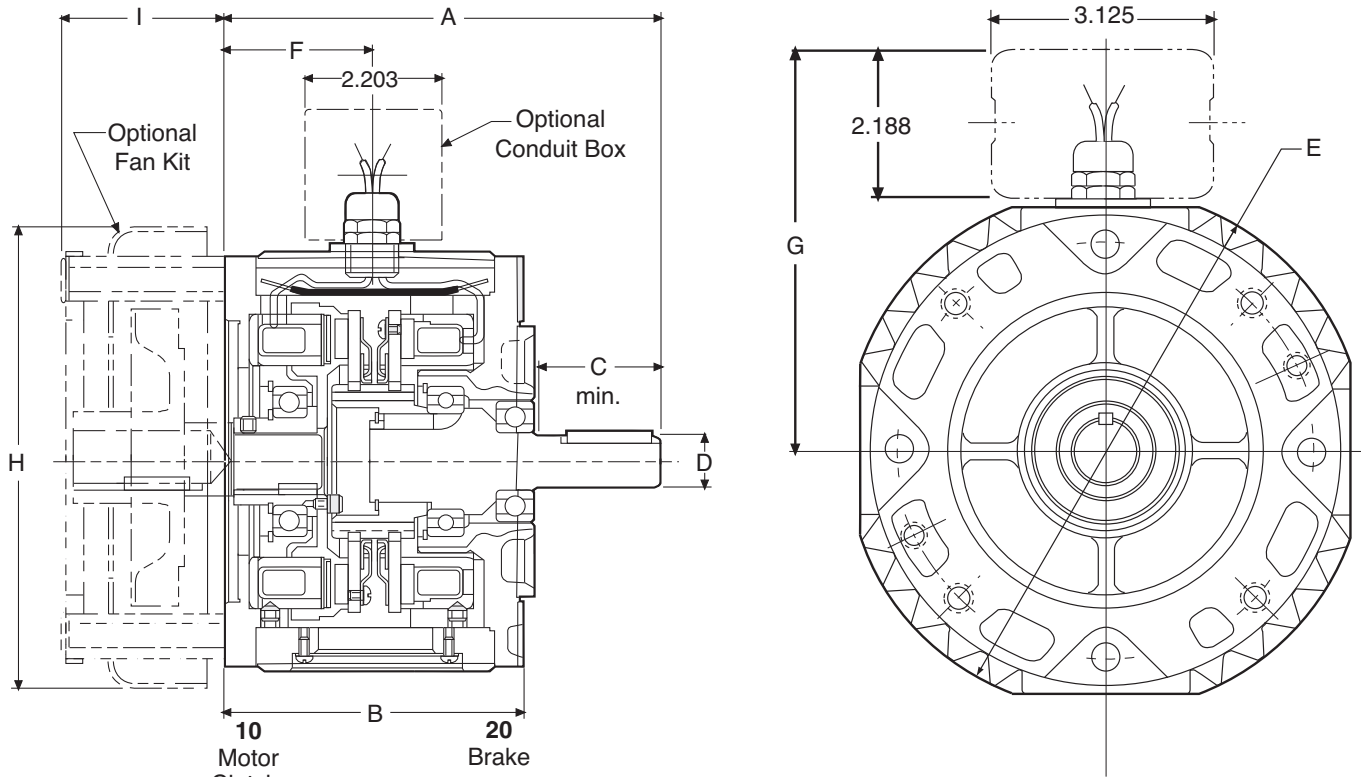

**Note:** Washdown Unimodules (EUM-W) do not have a finned housing.

### EUM 1020 Motor mounted UniModules

Size	A	B	C	D	E		F	G	H	I
					EUM	EUM-W				
50	6.750	4.844	1.813	.625	7.270	6.915	2.427	5.936	7.687	2.430
100	6.750	4.844	1.890	.625	7.270	6.915	2.427	5.936	7.687	2.430
180	6.828	4.844	1.890	.875	7.270	6.915	2.427	5.936	7.687	2.430
210	8.891	5.922	2.500	1.125	10.000	10.00	3.053	7.146	10.187	3.375
215	8.891	5.922	2.500	1.375	10.000	10.00	3.053	7.146	10.187	3.375

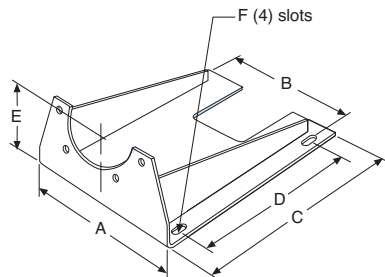

### Motor Mount (M)

Size	A	B	C	D	E	F	Part No.	
							EUM	EUM-W
50	9.250	8.250	11.000	8.000	3.500	.796 x .406	5370-101-010	5370-101-048
100	9.250	8.250	11.000	8.000	3.500	.796 x .406	5370-101-010	5370-101-048
180	9.250	8.250	11.000	8.000	4.500	.796 x .406	5370-101-012	5370-101-049
210	11.500	10.500	12.000	9.000	5.250	.750 x .406	5371-101-012	5371-101-026
215	11.500	10.500	12.000	9.000	5.250	.750 x .406	5371-101-012	5371-101-026

# Enclosed UniModule Combinations

## Dimensions EUM-2030

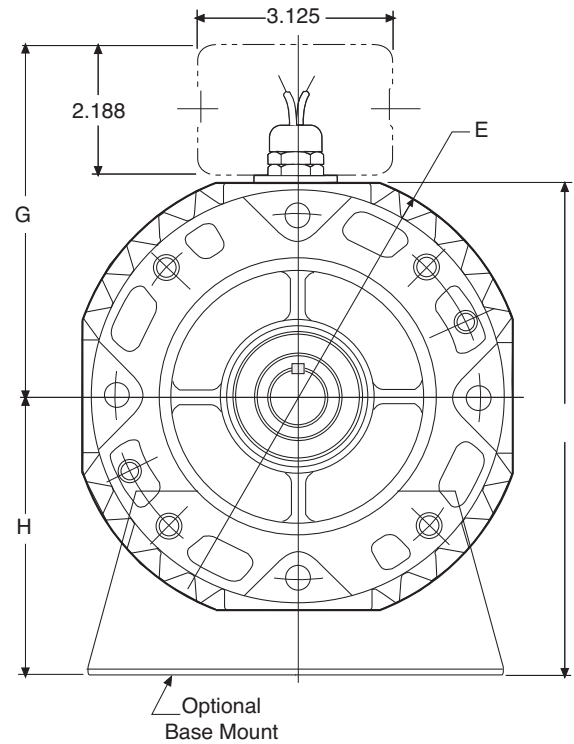
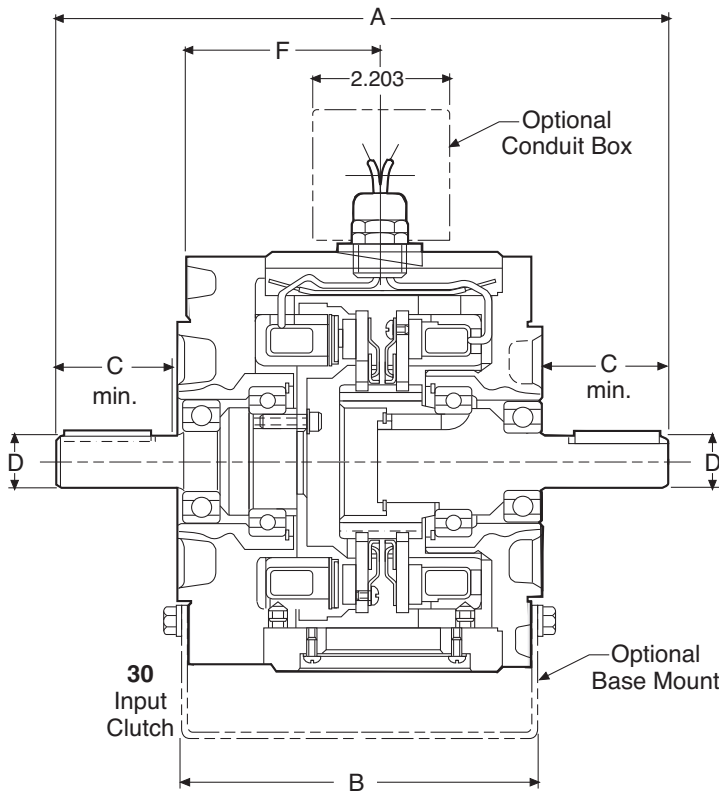

**Note:** Washdown UniModules (EUM-W) do not have a finned housing.

### EUM 2030 Base mounted UniModules

Size	A	B	C	D	E		F	G	H	I
					EUM	EUM-W				
50	9.516	5.719	1.813	.625	7.270	6.915	3.164	5.936	3.670	7.119
180	9.516	5.719	1.890	.875	7.270	6.915	3.164	5.936	4.484	8.119
210	12.969	7.719	2.500	1.125	10.000	10.00	4.514	7.146	5.234	10.234

### Base (B)

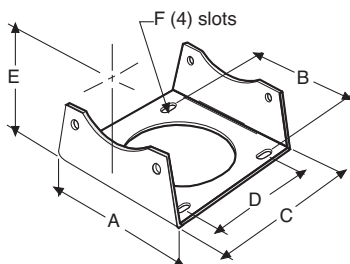

Size	A	B	C	D	E	F	Part No.	
							EUM	EUM-W
50	6.000	5.000	5.672	4.000	2.171	.750 x .406	5370-101-062	5370-101-046
100	6.000	5.000	5.672	4.000	2.171	.750 x .406	5370-101-062	5370-101-046
180	6.625	5.000	5.672	4.000	3.000	.750 x .406	5370-101-002	5370-101-047
210	9.000	7.750	8.203	6.000	3.375	.750 x .531	5371-101-001	5371-101-025
215	9.000	7.750	8.203	6.000	3.385	.750 x .531	5371-101-001	5371-101-025

# Enclosed UniModule Parts List

## 1020 Combinations

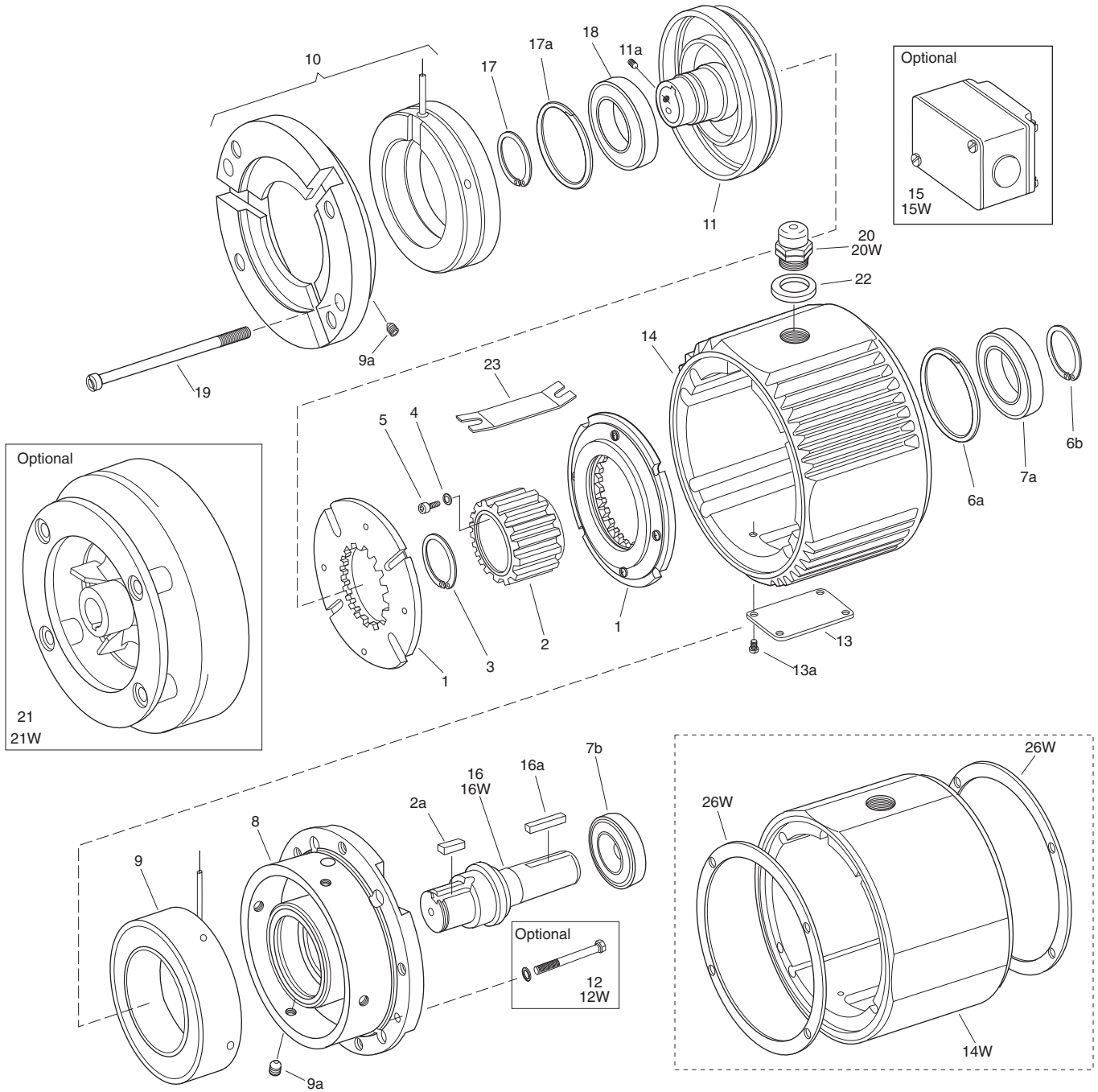

Specifications	EUM-50	EUM-100	EUM-180	EUM-210	EUM-215
Voltage – DC	6, 24 or 90	6, 24 or 90	6, 24 or 90	6, 24 or 90	6, 24 or 90
Static Torque – lb.ft.	16	30	30	95	95
Maximum Speed – RPM	3600	3600	3600	3600	3600
Average Weight – lbs.	10.0	13.2	13.2	30.6	30.6
Total cycled inertia – WR <sup>2</sup> (lb.ft. <sup>2</sup> )	.017	.041	.041	.20	.202

## UniModule Assemblies

Unit Size	Voltage	Part Numbers Enclosed (EUM)	Washdown EUM-W)	Unit Size	Voltage	Part Numbers Enclosed (EUM)	Washdown (EUM-W)
		UniModule	UniModule			UniModule	UniModule
50-1020	6V	5370-273-058	5370-273-100	210-1020	6V	5371-273-028	5371-273-056
	24V	5370-273-059	5370-273-101		24V	5371-273-029	5371-273-057
	90V	5370-273-057	5370-273-099		90V	5371-273-027	5371-273-055
100-1020	6V	5370-273-092	5370-273-108	215-1020	6V	5371-273-048	5371-273-064
	24V	5370-273-093	5370-273-109		24V	5371-273-049	5371-273-065
	90V	5370-273-091	5370-273-107		90V	5371-273-047	5371-273-063
180-1020	6V	5370-273-066	5370-273-116				
	24V	5370-273-067	5370-273-117				
	90V	5370-273-065	5370-273-115				

## Component Parts

Item	Description	EUM-50	EUM-100	EUM-180	EUM-210	EUM-215
1	Armature Assembly	5370-111-011 (2)	5370-111-013 (2)	5370-111-013 (2)	5371-111-005 (2)	5371-111-005 (2)
2	Armature Hub	540-1638	540-1642	540-1642	540-0741	540-0741
2a	Key	590-0043	590-0084	590-0084		
3	Retaining Ring	748-0445	748-0676	748-0676		
4	Lockwasher				950-0121 (6)	950-0121 (6)
5	Capscrew				797-0081 (6)	797-0081 (6)
6a	Retaining Ring	748-0113 (2)	748-0101	748-0101	748-0112	748-0112
6b	Retaining Ring				748-2002	748-2002
7a	Ball Bearing	166-0149	166-0101	166-0101	166-0142	166-1042
7b	Ball Bearing	166-0155	166-0143	166-0143	166-0144	166-0144
8	Endbell/Brake	456-1014	456-1019	456-1019	456-1017	456-1017
9	Brake Magnet					
	6 Volt	5370-631-037	5370-631-002	5370-631-002	5371-631-002	5371-631-002
	24 Volt	5370-631-038	5370-631-005	5370-631-005	5371-631-005	5371-631-005
	90 Volt	5370-631-036	5370-631-003	5370-631-003	5371-631-003	5371-631-003
9a	Set Screws	797-0471 (4)	797-1386 (4)	797-1386 (4)	797-0103 (4)	797-0103 (4)
10	Clutch Field/End Bell Assembly					
	6 Volt	5370-451-077	5370-451-086	5370-451-086	5371-451-033	5371-451-044
	24 Volt	5370-451-078	5370-451-087	5370-451-087	5371-451-034	5371-451-045
	90 Volt	5370-451-076	5370-451-085	5370-451-085	5371-451-032	5371-451-046
11	Rotor/Hub Assembly	5370-751-023	5370-751-035	5370-751-024	5371-751-014	5371-751-028
11a	Set Screws	797-1098 (2)	797-1249 (2)	797-1249 (2)	797-1098 (2)	797-1098 (2)
12	Mounting Accessory Kit	5370-101-040	5370-101-040	5370-101-040	5371-101-040	5371-101-024
13	Cover Plate	686-1055	686-1055	686-1055	686-1055	686-1055
13a	Cover Plate Screws	797-0575 (4)	797-0575 (4)	797-0575 (4)	797-0575 (4)	797-0575 (4)
14	Center Housing	535-0176	535-0176	535-0176	535-0177	535-0177
15	Conduit Box	5370-101-042	5370-101-042	5370-101-042	5370-101-042	5370-101-042
16	Shaft	798-0046	798-0128	798-0085	798-0051	798-0255
16a	Key	590-0029	590-0029	590-0029	590-0019	590-0124
17	Retaining Ring	748-0101 (2)	748-0101	748-0101	748-0558	748-0558
17a	Ball Bearing	166-0150	166-0300	166-0300	166-0168	166-0168
18	Retaining Ring	748-0018	748-0018	748-0018	748-0067	748-0067
19	Assembly Bolts	797-1433 (2)	797-1433 (2)	797-1433 (2)	797-1438 (2)	797-1438 (2)
20	Connector	280-0038	280-0038	280-0038	280-0038	280-0038
21	Accessory Fan	5370-101-055	5370-101-055	5370-101-054	5371-101-029	5371-101-034
22	Washer	950-0441	950-0441	950-0441	950-0441	950-0441
23	Insulator	572-0327	572-0327	572-0327	572-0327	572-0327
<b>EUM-W Unique Parts</b>						
12W	Washdown Mounting Kit	5370-101-052	5370-101-052	5370-101-052	5371-101-041	5371-101-028
14W	Center Housing for Washdown	535-0181	535-0181	535-0181	535-0182	535-0182
15W	Conduit Box Kit	5370-101-045	5370-101-045	5370-101-045	5370-101-045	5370-101-045
16W	Shaft	798-0263	798-0265	798-0262	798-0259	798-0267
20W	Conduit Connector	280-0058	280-0058	280-0058	280-0058	280-0058
21W	Fan Kit	5370-101-060	5370-101-060	5370-101-061	5371-101-033	
26W	Gasket/Seal Repair Kit	5370-101-058	5370-101-058	5370-101-058	5371-101-032	5371-101-032

# Enclosed UniModule Parts List

## 2030 Combinations

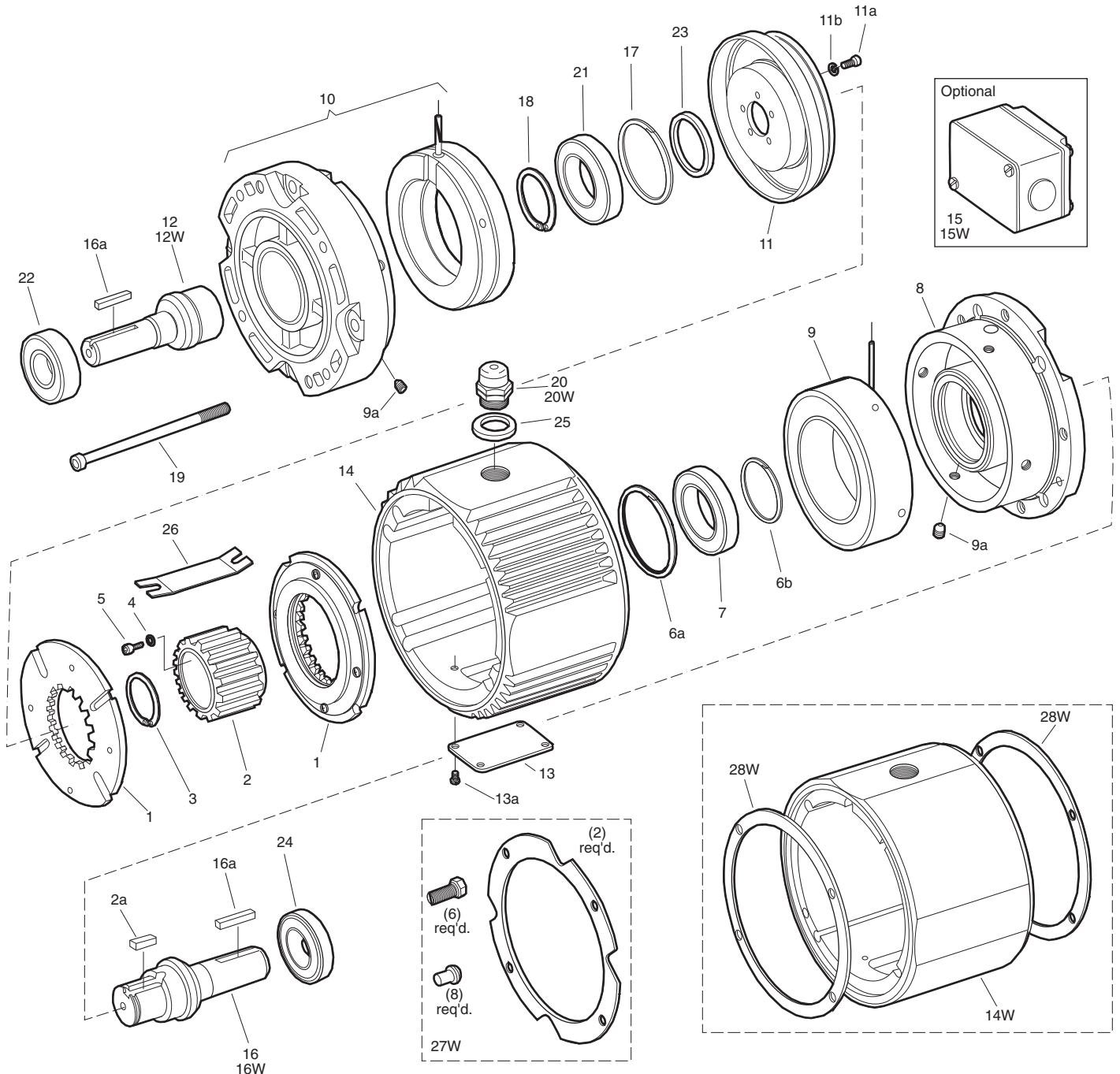

### Specifications

	EUM-50	EUM-180	EUM-210
Voltage – DC	6, 24 or 90	6, 24 or 90	6, 24 or 90
Static Torque – lb.ft.	16	30	95
Maximum Speed – RPM	3600	3600	3600
Average Weight – lbs.	13	16.5	41.3
Total cycled inertia – WR <sup>2</sup> (lb.ft. <sup>2</sup> )	.017	.041	.20

## UniModule Assemblies

Unit Size	Voltage	Part numbers Enclosed (EUM) UniModule	Washdown (EUM-W) UniModule
50-2030	6V	5370-273-062	5370-273-104
	24V	5370-273-063	5370-273-105
	90V	5370-273-061	5370-273-103
180-2030	6V	5370-273-070	5370-273-120
	24V	5370-273-071	5370-273-121
	90V	5370-273-069	5370-273-119
210-2030	6V	5371-273-032	5371-273-060
	24V	5371-273-033	5371-273-061
	90V	5371-273-031	5371-273-059

## Component Parts

Item	Description	EUM-50	EUM-180	EUM-210
1	Armature Assembly	5370-111-011 (2)	5370-111-013 (2)	5371-111-005 (2)
2	Armature Hub	540-1638	540-1642	540-0741
2a	Key	590-0043	590-0084	
3	Retaining Ring	748-0445	748-0676	
4	Lockwasher			950-0121 (6)
5	Capscrew			797-0081 (6)
6a	Retaining Ring	748-0113	748-0101	748-0112
6b	Retaining Ring			748-2002
7	Ball Bearing	166-0149	166-0101	166-0142
8	Endbell/Brake	456-1014	456-1019	456-1017
9	Brake Magnet			
	6 Volt	5370-631-037	5370-631-002	5371-631-002
	24 Volt	5370-631-038	5370-631-005	5371-631-005
	90 Volt	5370-631-036	5370-631-003	5371-631-003
9a	Set Screws			
10	Clutch Field/End Bell Assembly			
	6 Volt	5370-451-082	5370-451-090	5371-451-002
	24 Volt	5370-451-083	5370-451-091	5371-451-005
	90 Volt	5370-451-081	5370-451-089	5371-451-003
11	Rotor	5370-751-033	5370-751-034	5371-751-006
11a	Screw	797-1294 (4)	797-1214 (5)	797-0081 (6)
11b	Washer	950-0102 (4)	950-0102 (5)	950-0121 (6)
12	Shaft/Clutch	798-0047	798-0124	798-0123
13	Cover Plate	686-1055	686-1055	686-1055
13a	Screws	797-0575 (4)	797-0575 (4)	797-0575 (4)
14	Center Housing	535-0176	535-0176	535-0177
15	Conduit Box	5370-101-042	5370-101-042	5370-101-042
16	Shaft/Brake	798-0046	798-0085	798-0051
16a	Key	590-0029 (2)	590-0029 (2)	590-0019 (2)
17	Retaining Ring	748-0113 (2)	748-0101	748-0112
18	Retaining Ring	748-0017		748-0202
19	Assembly Bolts	797-1477 (2)	797-1477 (2)	797-1476 (2)
20	Connector	280-0038	280-0038	280-0038
21	Bearing	166-0149	166-0101	166-0142
22	Bearing	166-0155	166-0143	166-0144
23	Spacer		807-0062	807-0061
24	Bearing	166-0155	166-0143	166-0144
25	Washer	950-0441	950-0441	950-0441
26	Insulator	572-0327	572-0327	572-0327
<b>EUM-W Unique Parts</b>				
12W	Shaft/Clutch	798-0264	798-0261	798-0260
14W	Center Housing for Washdown	535-0181	535-0181	535-0182
15W	Conduit Box Kit	5370-101-045	5370-101-045	5370-101-045
16W	Shaft/Brake	798-0263	798-0262	798-0259
20W	Conduit Connector	280-0058	258-0058	258-0058
27W	Washdown Mounting Kit	5370-101-051	5370-101-051	5371-101-027
28W	Gasket/Seal Repair Kit	5370-101-058	5370-101-058	5371-101-032

# Warranty

Warner Electric LLC warrants that it will repair or replace (whichever it deems advisable) any product manufactured and sold by it which proves to be defective in material or workmanship within a period of one (1) year from the date of original purchase for consumer, commercial or industrial use.

This warranty extends only to the original purchaser and is not transferable or assignable without Warner Electric LLC's prior consent.

Warranty service can be obtained in the U.S.A. by returning any defective product, transportation charges prepaid, to the appropriate Warner Electric LLC factory. Additional warranty information may be obtained by writing the Customer Satisfaction Department, Warner Electric LLC, 449 Gardner Street, South Beloit, Illinois 61080, or by calling 815-389-3771.

A purchase receipt or other proof of original purchase will be required before warranty service is rendered. If found defective under the terms of this warranty, repair or replacement will be made, without charge, together with a refund for transportation costs. If found not to be defective, you will be notified and, with your consent, the item will be repaired or replaced and returned to you at your expense.

This warranty covers normal use and does not cover damage or defect which results from alteration, accident, neglect, or improper installation, operation, or maintenance.

Some states do not allow limitation on how long an implied warranty lasts, so the above limitation may not apply to you.

Warner Electric LLC's obligation under this warranty is limited to the repair or replacement of the defective product and in no event shall Warner Electric LLC be liable for consequential, indirect, or incidental damages of any kind incurred by reason of the manufacture, sale or use of any defective product. Warner Electric LLC neither assumes nor authorizes any other person to give any other warranty or to assume any other obligation or liability on its behalf.

WITH RESPECT TO CONSUMER USE OF THE PRODUCT, ANY IMPLIED WARRANTIES WHICH THE CONSUMER MAY HAVE ARE LIMITED IN DURATION TO ONE YEAR FROM THE DATE OF ORIGINAL CONSUMER PURCHASE. WITH RESPECT TO COMMERCIAL AND INDUSTRIAL USES OF THE PRODUCT, THE FOREGOING WARRANTY IS IN LIEU OF AND EXCLUDES ALL OTHER WARRANTIES, WHETHER EXPRESSED OR IMPLIED BY OPERATION OF LAW OR OTHERWISE, INCLUDING, BUT NOT LIMITED TO, ANY IMPLIED WARRANTIES OF MERCHANTABILITY OR FITNESS.

Some states do not allow the exclusion or limitation of incidental or consequential damages, so the above limitation or exclusion may not apply to you. This warranty gives you specific legal rights and you may also have other rights which vary from state to state.

## Changes in Dimensions and Specifications

All dimensions and specifications shown in Warner Electric catalogs are subject to change without notice. Weights do not include weight of boxing for shipment. Certified prints will be furnished without charge on request to Warner Electric.



**Warner Electric**  
31 Industrial Park Road • New Hartford, CT 06057  
815-389-3771 • Fax: 815-389-2582  
[www.warnerelectric.com](http://www.warnerelectric.com)