

**Bibbigard®
TLM Modules**



Bibby Turboflex™ Torque Limiting Modules have been specifically designed to provide overload protection for applications where very high torques are transmitted, and to extend the range of manual reset Bibbigard® Torque Limiters.

The modular system provides the capability for virtually unlimited torque capacity and lends itself to many transmission applications – chain, belt and gear drives, or shaft-to-shaft gear or flexible coupling drives.

The maximum release torque depends on the number and size of Torque Limiting Modules that can be incorporated, and the size of the unit that can be accommodated within the confines of the installation. Internally and externally adjusted modules provide repeatability better than 5%, however externally adjusted modules are preferred when the application is required to operate with minimal variation between static and dynamic disengagement.

CONSTRUCTION

The Bibbigard Torque Limiting Module is constructed from the finest quality materials. Many of the vital components are made from high quality tool steels, through hardened to Rockwell C62, and precision ground to close tolerances.

NORMAL OPERATION

The flange connection is driven by a large steel ball (2), located in the detent pocket (1), which is retained by a plunger (3). This in turn is retained axially by means of a system of angled races (5,7) biased by pressure from the Belleville springs (4), acting on a circle of balls (6).

DISENGAGEMENT

On overload, relative angular movement between the flanges imparts a tangential force (F_u) on the large steel ball, forcing it clear of the detent pocket back against the plunger. This in turn causes the plunger to be forced through the circle of balls overcoming the spring loading on the angle races. In this position, the balls are resting on the large diameter of the plunger, and once this condition is reached the flanges are completely free to rotate independently.

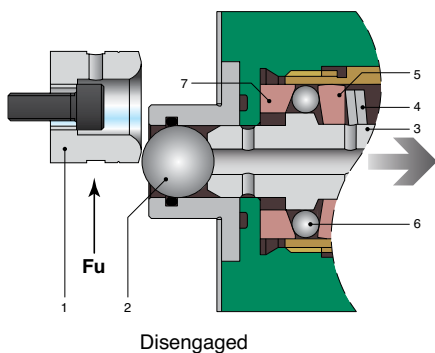

A suitable switch can be incorporated in the assembly to switch off the drive motor or operate a warning device when the Torque Limiting assembly disengages. After first ensuring that the drive is isolated, resetting is a simple matter of first realigning the flanges and then tapping each module plunger back with a soft mallet to allow the circle of balls to return to their original position and the large steel ball to return to its location in the detent pocket.

DETENT POCKETS

Internally and externally adjusted modules can be through-hole or blind-hole detent fixing (see diagrams on opposite page). The type of detent fixing is dependent upon the design constraints.

The mechanical clearance in the Module assembly should be eliminated by pre-loading the detent pocket (1) against the driving ball (2). This is achieved for the respective type of detent pocket under Adjustment (on the opposite page).

SELECTION

To apply the modules in the form of a torque limiter it is necessary to determine the quantity of modules needed for the required torque capacity at a specific radius from the axis of rotation.

$$\text{No. of modules} = \frac{\text{Torque (Nm)} \times 1000}{F_u \text{ (N)} \times \text{radius (mm)} \times K}$$

$K = 0.65$ for General Applications

$K = 0.5$ for Steelwork Applications

SPECIAL DESIGNS

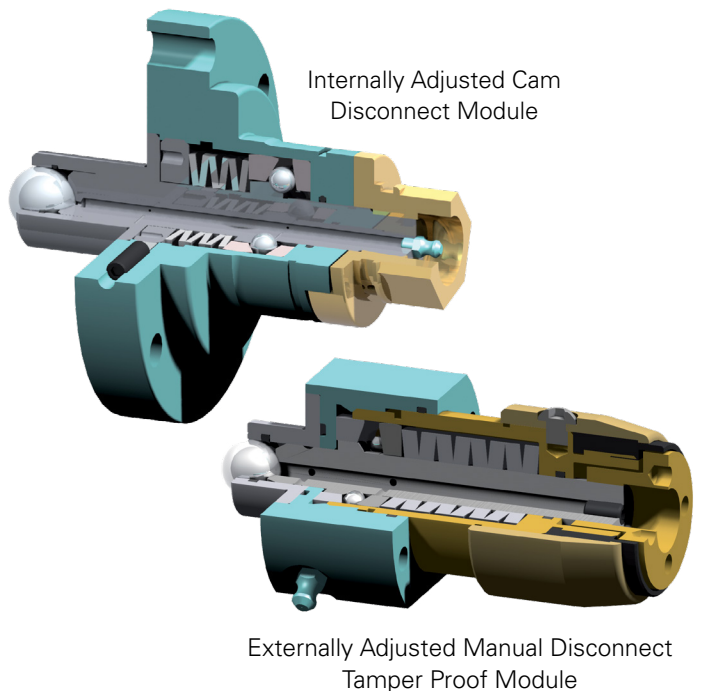

Bibbigard® Internally Adjusted Modules

ADJUSTMENT

Adjustment of the tangential force F_u , can be made by removing the unit from the mounting flange and adjusting the screw (3), so altering the spring force.

This procedure discourages tampering by unauthorized personnel.

Ensure that on assembly any clearance between the driving ball and the detent pocket is eliminated by tightening the adjusting screw located in the plate at the base of the detent pocket.

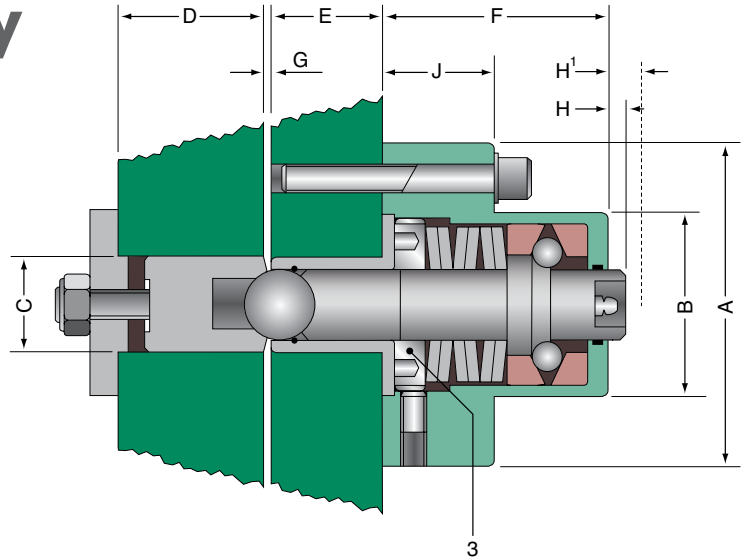

Model Number	Tangential Force F_u		Dimensions (mm)									
	lbf	N	A	B	C	D	E	F	G	H	H'	J
SE5BA	2,250	10,000	56	36	19.5	20	14	44	1.8	2.5	6	19
SE10BA	4,000	17,800	66	40	25	25	16	54.5	1.5	20	24	30
SE20BA	11,000	48,900	105	66	35	45	45	72	2	5	13	35
SE30BA	38,000	169,000	170	120	70	45	45	130	3	9	23	40
SE55BA	108,000	480,000	278	194	140	110	100	200	4	31	56	75

Note internal specifications may vary between sizes

Bibbigard Externally Adjusted Modules

ADJUSTMENT

Adjustment of the tangential force F_u , can be made by adjusting the spring housing (9), so altering the spring force.

Ensure that on assembly any clearance between the driving ball and detent pocket is eliminated by adjusting the quantity of shims (8) under the clamp face of the module.

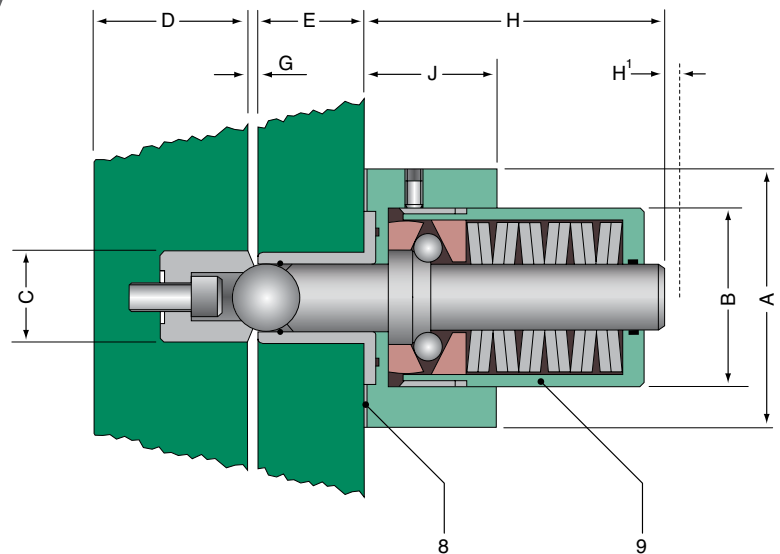

Model Number	Tangential Force F_u		Dimensions (mm)									
	lbf	N	A	B	C	D	E	F	G	H	H'	J
SE5EA	2,250	10,000	56	50	19.5	15	14	—	1.5	67	3.5	20
SE10EA	4,000	17,800	66	50	24.5	20	16	—	2.5	77	4	37
SE20EA	5,900	26,000	105	69	35	35	45	—	2.5	107	8	15
SE25EA	10,000	45,000	105	74	35	35	45	—	2.5	115	8	10

Note internal specifications may vary between sizes

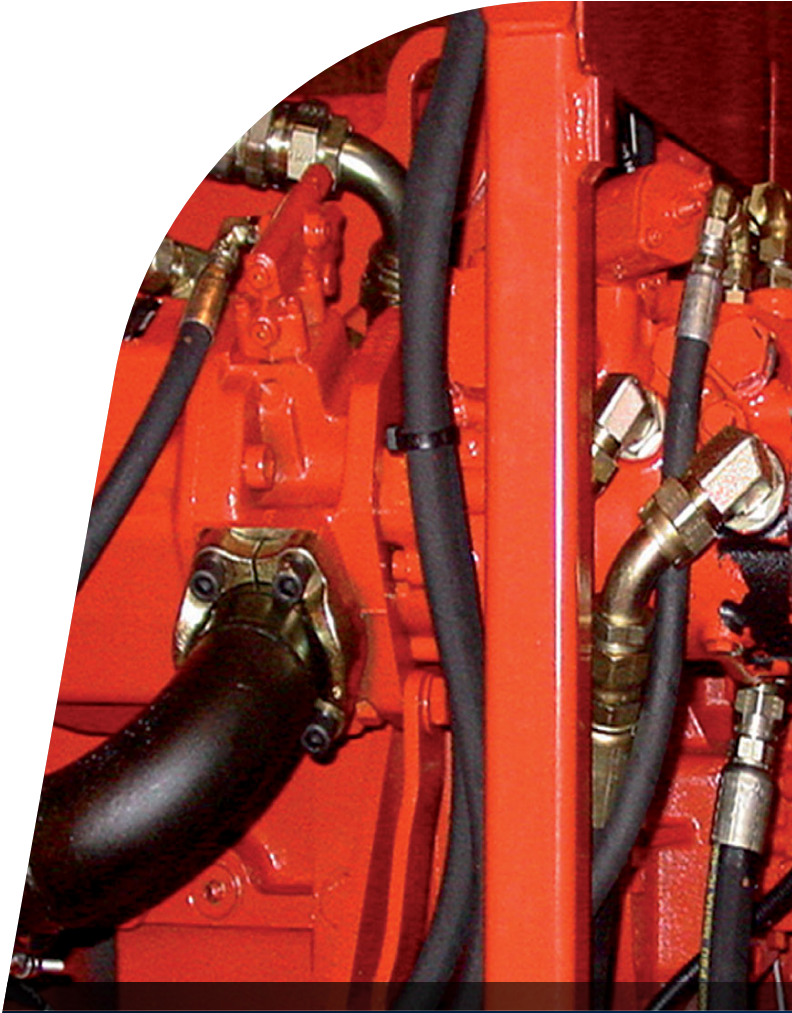

BIBBY TURBOFLEX™

Regal Rexnord

bibbyturboflex.com

Customer Service: 800-626-2120

Technical Service: 800-626-2093

CustomerService.PTSolutions@regalrexnord.com

regalrexnord.com

The proper selection and application of products and components, including assuring that the product is safe for its intended use, are the responsibility of the customer. To view our Application Considerations, please visit <https://www.regalrexnord.com/Application-Considerations>.

To view our Standard Terms and Conditions of Sale, please visit <https://www.regalrexnord.com/Terms-and-Conditions-of-Sale> (which may redirect to other website locations based on product family).

"Regal Rexnord" is not indicative of legal entity. Refer to product purchase documentation for the applicable legal entity. Regal Rexnord, Bibbigard and Bibby Turboflex are trademarks of Regal Rexnord Corporation or one of its affiliated companies. © 2019, 2025 Regal Rexnord Corporation, All Rights Reserved. MCB-P-1942-BB-US 04/25

 **RegalRexnord™**